



T Series, ST Series

Improved Sensitivity with eDrive™

Enhanced Brand Protection

Optimized Process Efficiency

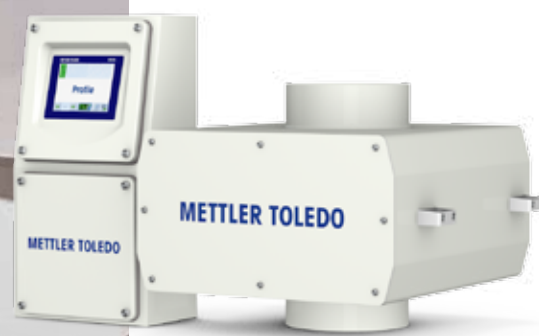

Metal Detection Solutions For Vertical Packaging Applications

METTLER TOLEDO

High Performance Metal Detection In Vertical Packing Applications

High-speed, vertical packaging processes need to maximize product quality, protect the welfare of customers and meet regulatory demands. When it comes to selecting a metal detection solution for the inspection of food products in vertical form, fill and seal (VFFS) processes, there can be only one choice: a METTLER TOLEDO Safeline Throat detector.

For the inspection of snack foods, confectionery and other food products packed using a multihead weigher and VFFS bagmaker, **T** and **ST** Series metal detectors are the ideal solution. These throat metal detectors provide the means to deliver significant benefits for your business.

Enhanced brand protection

The combination of increased sensitivity and superior reliability provide protection for brands and reputations.

Choosing the latest Safeline throat metal detectors can help achieve compliance with regulatory and industry standards and maximize product quality.

Increased productivity

T and **ST** Series metal detectors enable productivity to be optimized. This effectiveness is realized through:

- Simple set-up and operation
- Reliable, consistent performance
- Reduced frequency of performance monitoring tests
- Low maintenance requirements

Reduced operational costs

T and **ST** Series technology lower overall lifetime costs by:

- Eliminating false rejects & product waste
- Optimizing testing processes to increase operator efficiency
- Minimized installation costs



All Safeline metal detectors support compliance with the GFSI standards and external codes of practice including: BRC (British Retail Consortium), IFS (International Featured Standard for Food), SQF (Safe Quality Food), FSSC 22000/PAS 220, major retailer codes of practice and key legislation including the Food Safety Modernization Act (FSMA).



Choosing the right solution for your working environment

T and **ST** Series metal detectors are particularly suitable in instances where metallized film packaging materials are used in VFFS bagging operations. Inspection of the product takes place immediately before it enters the bag, overcoming limitations created by the wrapping material to ensure that the highest levels of sensitivity are achieved.

Detectors are available in a choice of finishes to suit all applications:

- Painted finish can be selected for use in dry, non-aggressive environments
- Stainless steel construction is available for more demanding applications
- A rugged stainless steel version with heavy duty sealing is available for the most challenging situations such as Individual Quick Frozen (IQF) product packaging applications



T and **ST Series** metal detectors can be seamlessly integrated with all leading weigher and bagmaker combinations. Zero metal free zone technology minimises insertion space between the multi-head weigher discharge chute and the tube of the VFFS bag maker, without compromising sensitivity performance.

Maximizing Product Quality

Meeting Compliance Requirements

T and ST Series metal detectors offer advanced metal detection solutions for vertical product inspection applications. When installed at Critical Control Points (CCPs), these metal detectors support HACCP and HARPC requirements, and the broader requirements of food safety regulations and standards. Set up is simple and a choice of easy to use, intuitive operator interfaces can be located either adjacent to, or remotely from, the metal detector.

Profile technology - advanced metal detection

T and ST Series metal detectors are available with METTLER TOLEDO Safeline's proprietary Profile software technology to provide advanced metal detection. The intuitive, easy to use interface simplifies procedures and places valuable process information at the fingertips of the whole manufacturing team.

Zero Metal Free Zone (ZMFZ) technology, Auto-Balance Control and Enhanced Noise and Vibration Immunity features deliver long term in-process performance and stability reducing the risk of false rejects, minimizing product waste and increasing operational efficiency.

eDrive™ delivers enhanced sensitivity

The latest Profile **T and ST Series** metal detectors are now supplied with integrated eDrive technology. eDrive delivers up to 20 percent improved spherical sensitivity in high volume, dry applications compared to previous Profile configurations. This means significantly smaller irregular shaped metal contaminants can be detected, enhancing overall product quality and protecting brand reputation.

Signature technology - for less demanding applications

T Series metal detectors are also available with METTLER TOLEDO Safeline's Signature operating platform and robust, push button membrane key panel operating system. Auto-Balance Control and on-board fault reporting combine to deliver a stable operating platform to reduce potential downtime.



Profile systems feature a large, full color touch screen interface with an icon driven menu.





Profile technology makes compliance easier

The use of ultra-high frequency operation combined with new eDrive technology enables the signals given off by all metallic contaminant types to be identified and amplified to aid detection and removal. Built-in software routines and data displays can be used to support quality management processes to meet compliance requirements.

Meeting compliance requirements



Missed performance monitoring tests can compromise quality standards and lead to non-compliance issues.

T and **ST Series** detectors with Profile technology advise when test routines need to be performed and when testing is overdue via highly visible screen messages.

Greater process control



The control of manufacturing processes is supported through an automated user access log facility. This feature enables data to be reviewed to establish when system access was made and by whom. This helps with the management of line personnel and ensures enhanced levels of due diligence can be exercised.

Ensuring uptime



T and **ST Series** detectors incorporate advanced Condition Monitoring technology which constantly analyzes and tracks the performance of major system components. Adverse trends are highlighted as an early warning in advance of potential failure enabling the issue to be addressed when the machine is off-line to avoid lost production time.

Easy System Integration

Optimized Process Efficiency

Optimizing process efficiency is essential to meet customers' demands and maximize business profitability. T and ST Series metal detectors are a flexible, easy to install solution offering a wide range of benefits to enhance productivity, minimize downtime and enhance worker safety.

Reduced frequency of routine performance monitoring

The **Reduced Test (RT)** feature monitors system performance to ensure the metal detector is always working to, or better than, the required specification. Increased confidence in the system then allows users to run the metal detector in a Reduced Test mode.

The frequency of routine performance monitoring testing can then be significantly reduced (subject to quarantine periods), leading to increased productivity and improved Overall Equipment Effectiveness (OEE). The operational costs of conducting the tests decrease dramatically as a result of extending the intervals between tests.



Case Study: 83% less performance monitoring testing

A typical snack food manufacturer has 24 weigher/bagger lines, running at an average speed of 100 bags per minute. The facility currently performs performance monitoring tests every 2 hours (12 times per day). Each test procedure takes 3 minutes, and results in the line stopping.

	Production Impact	
	Testing Every 2 Hours* (current)	Testing every 12 hours* (running in reduced test mode)
Production time lost per day:	3 minutes x 12 times per day x 24 lines = 864 minutes	3 minutes x 2 times per day x 24 lines = 144 minutes
Product packs lost per day:	864 minutes x 100 bags per minute = 86k bags	144 minutes x 100 bags per minute = 14k bags
Product packs lost per year:	86400 bags x 350 days = 30m bags	14400 bags x 350 days = 5m bags

Results from using Reduced Test mode, and reducing tests from 12/day to 2/day:

- 25 million additional packs produced per year
- 4200 hours or 175 man days saved annually

*Subject to quarantine periods and site-specific operating conditions

Improved test repeatability and reduced testing time

The optional **ATS - Auto Test System** ensures tests are conducted consistently, every time, for multiple metal types to improve process quality. Worker safety is improved by removing the need for a line operator to manually drop a test sample through the aperture which often requires working at height or stretching across other production line equipment.

The **ATS - Auto Test System** is a self-contained unit consisting of either 3 or 4 tubes with integrated metal test samples. Options include ferrous, non-ferrous, stainless steel and aluminium.

A simple push of a button and the test sample shuttles are passed through the aperture in succession in a controlled manner.

The time required to conduct a routine performance monitoring test is reduced significantly to less than 30 seconds per line, enhancing operator efficiency and increasing production line uptime.

The ATS is available as a retro-fittable option on many Safeline T and ST Series metal detectors.

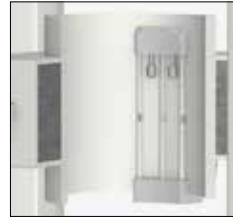

Cross-sectional view of an installed ATS system.



An on screen message confirms the test status for each metal type. The green light indicates a pass.



Remote access and control from networked devices

Access to the metal detector data records is essential for quality management processes to meet compliance requirements. Having this data easily accessible, and being able to quickly and easily perform required processes, improves operational efficiency. Due to the installation location of the metal detector, this has often been a challenge, both for line operators and Quality Managers. However, by leveraging industry standard Virtual Network Computing (VNC) protocols, **Emulation technology** can now simplify access to the Profile metal detector HMI panel to deliver operational efficiencies and improve worker safety.



Emulation software can be specified on all Profile T and ST Series metal detectors.

Using a VNC client, Emulation enables users to extend and remotely control the Profile HMI for enhanced system integration and increased operator efficiency.

By connecting over an internal network, users can interact with and monitor the performance of multiple Profile metal detectors on remote devices including mobile phones, tablets, laptops and computers. Emulation software is compatible with Android, iOS, Linux, Mac and Windows devices.

Meet Compliance Requirements Enhance Levels of Automation

To comply with the latest regulations and quality standards, it is no longer sufficient to rely on paper based record keeping processes. Many major retailers now insist that records are stored electronically. Innovative **ProdX™** software automatically collects the critical inspection process data you need in one convenient location, significantly reducing the need to interact directly with the Critical Control Points on the factory floor.

Record Keeping for Compliance

ProdX software delivers an automated, reliable and comprehensive solution to electronic record keeping. The latest metal detector test processes including those recommended by major retailer groups are incorporated into the software as standard.

Also included is the ability to track incidents (rejects, alarms and warnings), and document both a corresponding reason and corrective action for compliance with food safety legislation.

Productivity

Centralized product set-up and changeovers reduces operator errors, shortens set-up time, and increases production uptime.

Quality

Dashboard monitoring provides early warning indication of key inspection process issues to ensure product quality is never compromised.

Security

Events monitoring tracks device alarms, events, and changes for process security. Robust user management means only authorized personnel have access to critical product and production information.

Clarity

Graphical user screens with machine state status icons, active reject monitoring by device, complete with comprehensive reporting capabilities ensure you have complete clarity of your product inspection program.



ProdX is scalable to meet your needs whether monitoring a single packaging line or monitoring numerous lines from multiple production sites and is supported by the largest team of Product Inspection sales and service professionals in the world.

Data Collection Options

Supporting Due Diligence Records

T and ST Series metal detectors can be configured to incorporate a full range of data collection options. These can be used to support requirements for electronic record keeping as well as enabling integration with factory management systems, making processes more streamlined, more accessible and more efficient.

USB Port

Incorporating a USB port enables information captured by the detector to be transferred simply and effectively to data storage devices such as a computer. It facilitates access to a range of standard and configurable reports, available in CSV, TSV and TXT formats for analysis or electronic data storage.

This eliminates the need for paper records and provides comprehensive process data to prove due diligence has been exercised and supports process improvement.

Ethernet Adapter

Provides network connectivity, utilizing a proprietary protocol for real time data transfer, collection and integration into factory management systems. This option is essential for OPC and ProdX integration.

Fieldbus Interface Module (FIM)

The FIM enables real time communication, data transfer and collection via industry-standard Fieldbus protocols including EtherNet/IP, Modbus TCP and Profinet IO.

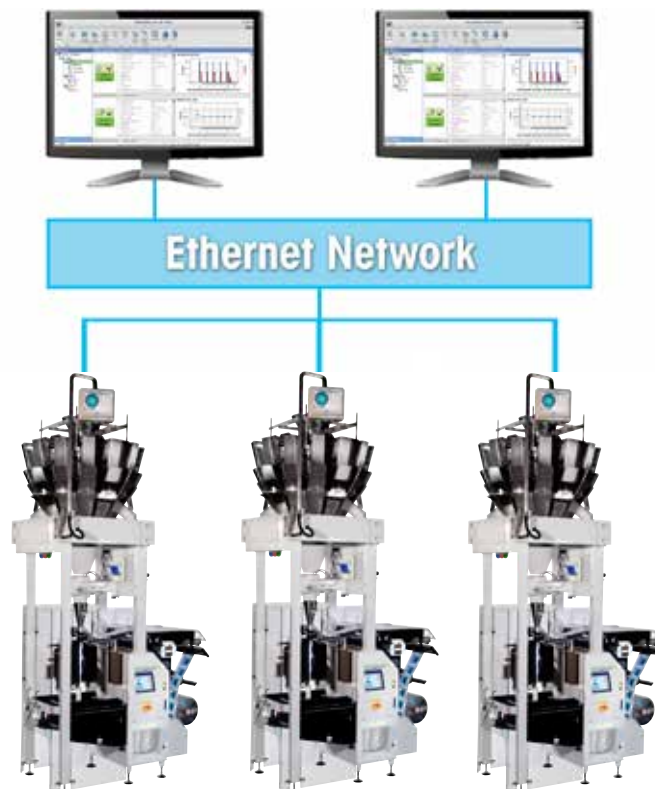

Sensitivity - Profile T and ST Series metal detectors

With eDrive™ technology

Sensitivities are given as a guide to performance and the data quoted is based on the Safeline “boost” performance algorithm being switched out. Achievable sensitivity will be dependent upon the product being inspected, the physical installation of the unit and the final specification of the model chosen. Further improvements in performance may be achieved in some installations by using the Safeline “boost” algorithm.

Model / Aperture	Fe	Non-Fe*	SS 316**
T100 / 100mm	0.5 mm	0.5 mm	0.8 mm
T125 / 125mm	0.6 mm	0.6 mm	0.8 mm
T150 / 150mm	0.7 mm	0.7 mm	0.9 mm
T175 / 175mm	0.8 mm	0.8 mm	1.1 mm
T200 / 200mm	1.0 mm	1.2 mm	1.3 mm
T225 / 225mm	1.1 mm	1.3 mm	1.4 mm
ST118 / 118mm	0.5 mm	0.5 mm	0.7 mm
ST148 / 148mm	0.5 mm	0.5 mm	0.8 mm
ST184 / 184mm	0.6 mm	0.6 mm	0.8 mm
ST200 / 200mm	0.6 mm	0.6 mm	0.9 mm
ST235 / 235mm	0.7 mm	0.8 mm	1.0 mm

* Non-Fe includes aluminium, brass, copper, phosphor bronze, etc.

** Stainless Steel sensitivities quoted are for “non-magnetic grades.”

T Series metal detectors are ideal for installation where insertion space is restricted. ST Series metal detectors offer enhanced sensitivity in applications where there is sufficient space to accommodate them. A T150 and an ST148 are pictured below for comparison purposes. All dimensions shown are in mm.

T Series (T150 shown - with 150mm aperture)

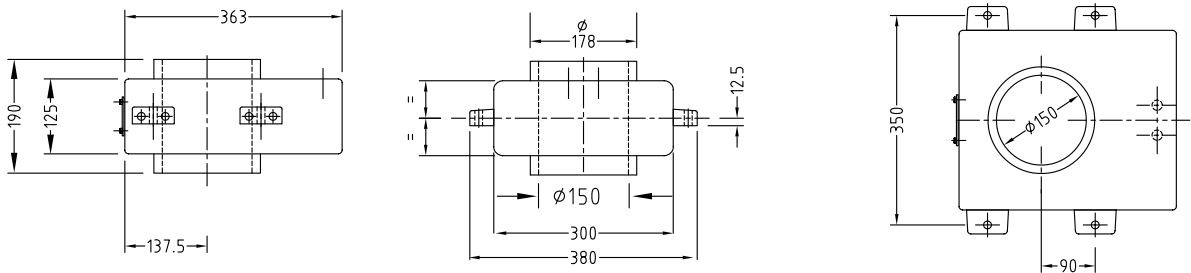



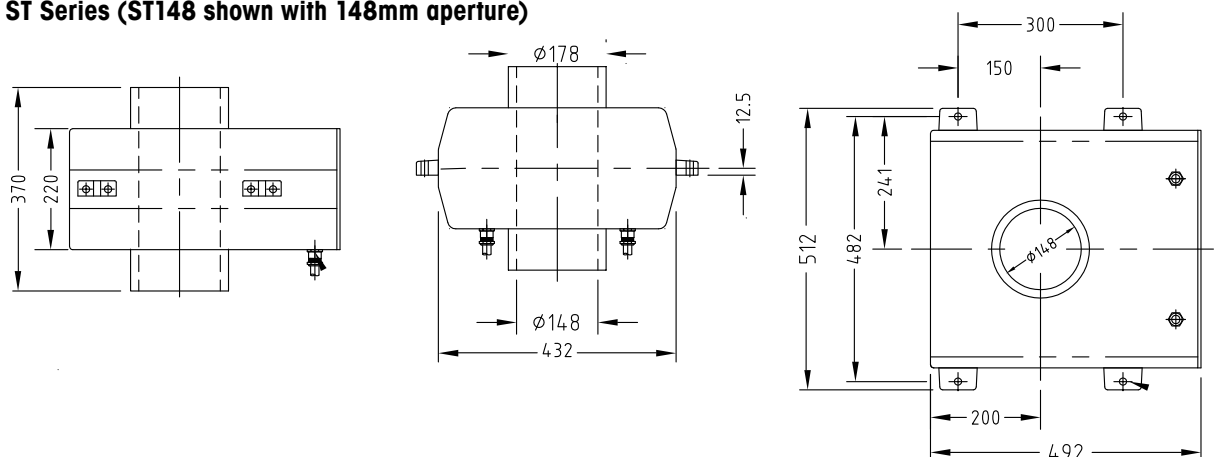

ST Series (ST148 shown with 148mm aperture)



Detecting smaller metal contaminants

For increased brand protection

T and ST Series metal detectors with eDrive Technology outperform conventional metal detection technology, enabling smaller metal contaminants to be found. The table below illustrates how a small improvement in spherical sensitivity can considerably reduce the lengths of wire type contaminants that can be detected.

Metal Detector Specification	316 Stainless Steel Sphere Size				316 Stainless Steel Wire Sample: 0.5mm diameter (worst orientation)			
	2.0 mm ●	1.5 mm ●	1.2 mm ●	1.0 mm ●	50mm long 	25mm long 	15mm long 	5mm long 
1.5mm Fe	✓	✗	✗	✗	✗	✗	✗	✗
1.2mm Fe	✓	✓	✗	✗	✗	✗	✗	✗
1.0mm Fe	✓	✓	✓	✗	✓	✓	✓	✗
0.8mm Fe	✓	✓	✓	✓	✓	✓	✓	✓

Images of spheres and wire lengths above are for illustrative purposes only, and may not be exactly to scale

System integration options

Tailored solutions to meet your requirements

Throat metal detectors provide the ultimate in flexibility and offer a high degree of customization for easy integration into any vertical packaging process regardless of the application. A design service is available to provide the necessary support frames and feed funnels to integrate T and ST Series metal detectors with all new and existing weigher bagger combinations.

Ancillary and support equipment available includes:

- Non-metallic feed funnels
- Fixed mounting brackets
- Sliding Frame detector mounting
- Swing Frame detector mounting

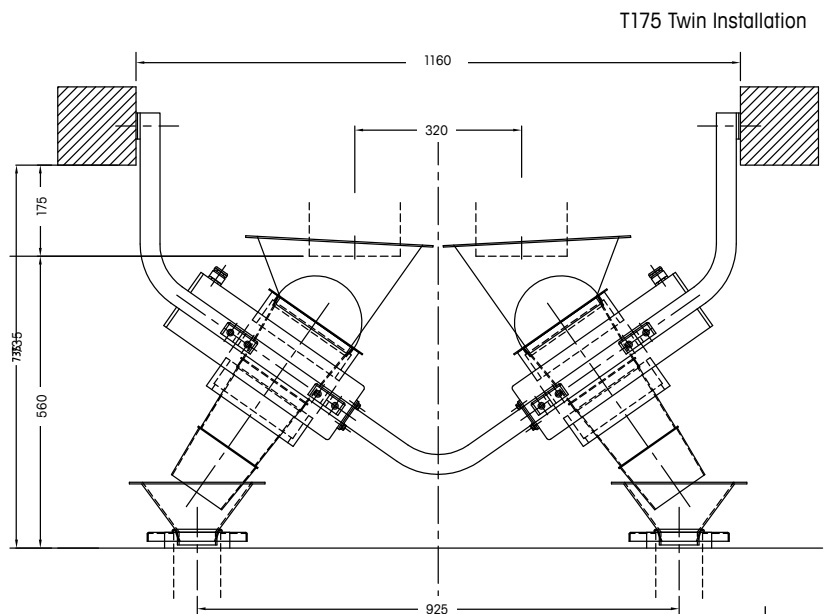
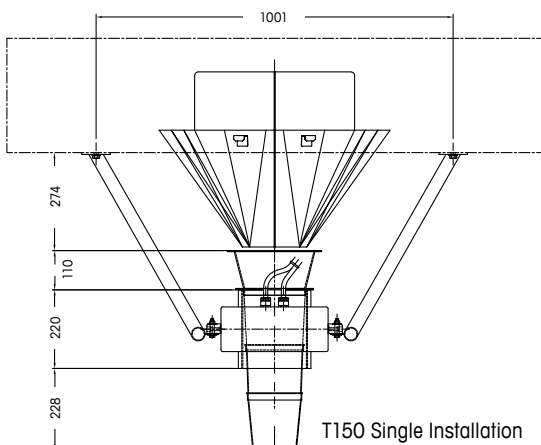

Benefit from Service

Global Reach and Local Excellence

METTLER TOLEDO Service helps you get the most out of your equipment and provides you with support when and where you need it. We can help you maximize the benefits and the return on investment of your metal detection equipment through its entire lifecycle. Whether you want to achieve improved uptime, better compliance, increased performance or enhanced expertise we can support you.

Uptime

- On-site support
- Spare Parts and Kits
- Repair service

Expertise

- User Training
- Documentation and downloads

Compliance

- Test Samples
- Equipment Qualification
- Performance Verification
- Compliance certificates

Performance

- Setup and configuration
- Professional installation
- Preventative Maintenance
- Upgrade and refurbishment

IPac™ – Creating the documentation to Support Compliance

METTLER TOLEDO Safeline metal detection systems are supplied with an IPac installation and performance verification package to support ongoing compliance with internal and external standards.

This comprehensive package provides full documentation for the installation, commissioning and verification process to meet all audit requirements.



www.mt.com/metaldetection

For more information

METTLER TOLEDO Group
Product Inspection Division
Local contact: www.mt.com/contacts

Subject to technical changes
© 03/17 METTLER TOLEDO. All rights reserved
SLMD-UK-BRO-EN-T/ST-0317