



Gravity Fall Systems

Improved Sensitivity with eDrive™

Tailored Solutions

Optimized Process Efficiency

Metal Detection Solutions

Powder and Granular Product Applications

Maximum Protection

Optimized Operational Efficiency

Designed to deliver ultimate product quality and total peace of mind for you and your customers, METTLER TOLEDO Safeline's Gravity Fall metal detection systems inspect free falling fine powdered and granular products for metal contamination. The combination of maximum detection capability, efficient rejection systems and new technology to optimize performance testing leads to increased operational efficiency, maximized profitability, and easier compliance with both industry standards and regulations.

High frequency operation and sophisticated electronic filtering techniques combine to deliver the ultimate in metal detection sensitivity within the product flow. On detection of metal, a fully automatic, high speed reject device operates, diverting the contaminated product and isolating it from the main product flow.

Enhanced brand protection

The combination of increased sensitivity and superior reliability provide protection for your brand and your reputation.

Choosing the latest Safeline Gravity Fall metal detection systems can help you achieve:

- Compliance with regulatory and industry standards
- Improved hygiene standards
- Maximized product quality

Increased productivity

Gravity Fall metal detection systems enable productivity to be optimized. This effectiveness is realized through:

- Simple set-up and operation
- Reliable, consistent performance
- Reduced frequency of performance monitoring tests
- Low maintenance requirements
- Easy clean system designs and integrated test facilities

Reduced manufacturing costs

Gravity Fall technology lowers overall lifetime costs by:

- Eliminating false rejects & product waste
- Optimizing testing processes to increase operator efficiency
- Minimized installation costs



All Safeline metal detectors support compliance with the GFSI standards and external codes of practice including: BRC (British Retail Consortium), IFS (International Featured Standard for Food), SQF (Safe Quality Food), FSSC 22000/PAS 220, major retailer codes of practice and key legislation including the Food Safety Modernization Act (FSMA).

Choosing the right solution for your product application

Gravity fall metal detection systems have been designed specifically for the inspection of free falling powders and granular products in non-pressurised applications. Reject devices are designed to be dismantled quickly and easily without the need for tools. This shortens clean down procedures to maximise production capacity. All reject devices are failsafe on power outage. Anti-static throughput tubes are supplied as standard to reduce the potential for static build up.



Y-Valve Gravity Fall systems are suitable for the inspection of powders and granular products. The Y-Valve's quick release and captive reject mechanism simplifies cleaning procedures whilst an internal seal helps to reduce product discharge into the reject channel.

Best for: applications with frequent product changeovers and when regular cleaning between production batches is required.



Sealtite systems features an innovative design to provide a dust tight seal. This virtually eliminates the escape of good product into the reject channel, reducing product waste.

Best for: high value, dusty products in explosive environments; applications where insertion space is limited.



Open Diverter technology provides a cost effective solution for non-dusty products, and can be upgraded to Sealtite standards retrospectively if required.

Best for: non dusty granular products where insertion space is limited.

Sealed to IP65 with a choice of finishes

Detectors are available in a choice of finishes to suit all applications:

- Painted finish can be selected for use in dry, non-aggressive environments
- Stainless steel construction is available for more demanding applications

Reliable, robust construction

Built for installation in tough environments, all METTLER TOLEDO Safeline Gravity Fall systems utilise fully welded stainless steel support frames and robust construction techniques.

This leads to low maintenance requirements and maximum reliability providing the lowest overall cost of ownership.

ATEX/IECEx compliance for explosive atmospheres

If operating in a potentially explosive atmosphere, certain Gravity Fall metal detection systems can be supplied to comply with ATEX/IECEx regulations. Please discuss your requirements with your local sales representative.



Maximizing Product Quality

Meeting Compliance Requirements

Gravity Fall systems offer advanced metal detection solutions for free falling powder and granular product inspection applications to provide product quality assurance. When installed at Critical Control Points (CCPs), these metal detection systems support HACCP and HARPC requirements, and the broader requirements of food safety regulations and standards.

Profile technology - advanced metal detection

All Gravity Fall metal detection systems are available with METTLER TOLEDO Safeline's proprietary Profile software technology to provide advanced metal detection. The intuitive, easy to use interface simplifies procedures and places valuable process information at the fingertips of the whole manufacturing team.

Auto-Balance Control and Enhanced Noise and Vibration Immunity features deliver long term in-process performance and stability reducing the risk of false rejects, minimizing product waste and increasing operational efficiency.



Profile systems feature a large, full color touch screen interface with an icon driven menu.

eDrive™ delivers enhanced sensitivity

The latest Profile metal detectors are now supplied with integrated eDrive technology which delivers up to 20 percent improved spherical sensitivity in high volume, dry applications compared to previous Profile configurations.

This means significantly smaller irregular shaped metal contaminants can be detected, enhancing overall product quality and protecting brand reputation.

Signature technology - for less demanding applications

Gravity Fall systems are also available with METTLER TOLEDO Safeline's Signature operating platform and robust, push button membrane key panel operating system. Auto-Balance Control and on board fault reporting combine to deliver a stable operating platform to reduce potential downtime.





Profile technology makes compliance easier

The use of ultra-high frequency operation combined with new eDrive technology enables the signals given off by all metallic contaminant types to be identified and amplified to aid detection and removal. Built-in software routines and data displays can be used to support quality management processes to meet compliance requirements.

Meeting compliance requirements



Missed performance monitoring tests can compromise quality standards and lead to non-compliance issues.

Gravity Fall metal detection systems with Profile technology advise when test routines need to be performed and when testing is overdue via highly visible screen messages.

Greater process control



The control of manufacturing processes is supported through an automated user access log facility. This feature enables data to be reviewed to establish when the system was accessed and by whom. This helps with the management of line personnel and ensures enhanced levels of due diligence can be exercised.

Ensuring Uptime



Gravity Fall metal detection systems incorporate advanced Condition Monitoring technology which constantly analyses and tracks the performance of major system components. Adverse trends are highlighted as an early warning in advance of potential failure enabling the issue to be addressed when the machine is off-line to avoid lost production time.

Flexible System Integration

Optimized Process Efficiency

Optimizing process efficiency is essential to meet the demands of customers and maximise business profitability. Gravity Fall metal detection systems are a flexible, easy to install solution offering a wide range of benefits to enhance productivity, minimize downtime and enhance worker safety.

Reduced frequency of routine performance monitoring

The **Reduced Test mode (RT)** feature monitors system performance to ensure the metal detector is always working to, or better than, the required specification. Increased confidence in the system then allows users to run the metal detector in a Reduced Test mode.

The frequency of routine performance monitoring can then be significantly reduced (subject to quarantine periods), leading to increased productivity and improved Overall Equipment Effectiveness (OEE). The operational costs of conducting the tests decrease dramatically as a result of extending the intervals between tests.



Application Illustration: Reduced Test Mode for inspection of specialty chemicals

A specialty chemical producer uses 6 Gravity Fall metal detection systems to inspect product immediately before filling into 1 tonne big bags across a 12 hour day, 6 days a week, and tests all 6 metal detectors every 2 hours. Due to the inaccessibility of the systems (installed at height before the big bag filling station) each time the systems are tested it takes 20 minutes to test all 6 machines and results in 20kg of wasted product per test.

	Production Impact	
	Testing Every 2 Hours* (current)	Testing every 12 hours* (running in Reduced Test mode)
Production time lost per day:	20 minutes/test x 6 times per day = 140 minutes	20 minutes/test x 2 times per day = 40 minutes
Product lost per day:	20 kg/test x 6 tests per day = 120 kg	20 kg/test x 2 tests per day = 40kg
Product lost per year:	120kg x 310 working days = 37.2 tonnes	40kg x 310 working days = 12.4 tonnes

Results from using Reduced Test mode, and reducing tests from 6/day to 1/day:

- 24.8 tonnes of additional product produced during the same period
- 413 man hours of labour saved - the equivalent of 34 working days

*Subject to quarantine periods and site-specific operating conditions

Integrated test facility simplifies testing procedure

Gravity Fall metal detection systems can be supplied with an integrated test facility. This optional extra provides an efficient means of testing metal detector performance and reject diverter operation.

The Integrated test facility enables a test sample to be introduced without interrupting production. The Integrated test grid ensures test samples are collected easily after routine performance monitoring and performance verification procedures.



Access port for test sample



Integrated test grid

Improved test repeatability and reduced testing time

The optional **ATS - Auto Test System** ensures tests are conducted consistently, every time, for multiple metal types to improve process quality. Performance testing can be completed in under 30 seconds.

ATS is a self-contained unit consisting of either 3 or 4 tubes with integrated metal test samples. Options include ferrous, non-ferrous, stainless steel and aluminium. A simple push of a button and the test sample shuttles are passed through the aperture in succession in a controlled manner.

Worker safety is improved by removing the need for a line operator to manually drop a test sample through the aperture which often requires working at height or stretching across other production line equipment.



An on screen message confirms the test status for each metal type. The green light indicates a pass.

Remote access and control from networked devices

Access to the metal detector data records is essential for quality management processes to meet compliance requirements. Having this data easily accessible, and being able to quickly and easily perform required processes, improves operational efficiency. Due to the installation location of the metal detector, this has often been a challenge, both for line operators and Quality Managers. However, by leveraging industry standard Virtual Network Computing (VNC) protocols, **Emulation technology** can now simplify access to the Profile metal detector HMI panel to deliver operational efficiencies and improve worker safety.



Emulation software can be specified on all Profile Gravity Fall metal detection systems.

Using a VNC client, Emulation enables users to extend and remotely control the Profile HMI for enhanced system integration and increased operator efficiency.

By connecting over an internal network, users can interact with and monitor the performance of multiple Profile metal detectors on remote devices including mobile phones, tablets, laptops and computers. Emulation software is compatible with Android, iOS, Linux, Mac and Windows devices.

Meet Compliance Requirements Enhance Levels of Automation

To comply with the latest regulations and quality standards, it is no longer sufficient to rely on paper based record keeping processes. Many major retailers now insist that records are stored electronically. Innovative **ProdX™** software automatically collects the critical inspection process data you need in one convenient location, significantly reducing the need to interact directly with the Critical Control Points on the factory floor.

Record Keeping for Compliance

ProdX software delivers an automated, reliable and comprehensive solution to electronic record keeping. The latest metal detector test processes including those recommended by major retailer groups are incorporated into the software as standard.

Also included is the ability to track incidents (rejects, alarms and warnings), and document both a corresponding reason and corrective action for compliance with food safety legislation.

Productivity

Centralized product set-up and changeovers reduces operator errors, shortens set-up time, and increases production uptime.

Quality

Dashboard monitoring provides early warning indication of key inspection process issues to ensure product quality is never compromised.

Security

Events monitoring tracks device alarms, events, and changes for process security. Robust user management means only authorized personnel have access to critical product and production information.

Clarity

Graphical user screens with machine state status icons, active reject monitoring by device, complete with comprehensive reporting capabilities ensure you have complete clarity of your product inspection program.



ProdX is scalable to meet your needs whether monitoring a single packaging line or monitoring numerous lines from multiple production sites and is supported by the largest team of Product Inspection sales and service professionals in the world.

Data Collection Options

Supporting Due Diligence Records

Gravity Fall metal detection systems can be configured to incorporate a full range of data collection options. These can be used to support requirements for electronic record keeping as well as enabling integration with factory management systems, making processes more streamlined, more accessible and more efficient.

USB Port

Incorporating a USB port enables information captured by the detector to be transferred simply and effectively to data storage devices such as a computer. It facilitates access to a range of standard and configurable reports, available in CSV, TSV and TXT formats for analysis or electronic data storage.

This eliminates the need for paper records and provides comprehensive process data to prove due diligence has been exercised and supports process improvement.

Ethernet Adapter

An Ethernet adapter provides network connectivity by using a proprietary protocol for real time data transfer, collection and integration into factory management systems. This option is essential for OPC and ProdX integration.

Fieldbus Interface Module (FIM)

The FIM enables real time communication, data transfer and collection via industry-standard Fieldbus protocols including EtherNet/IP, Modbus TCP and Profinet IO.

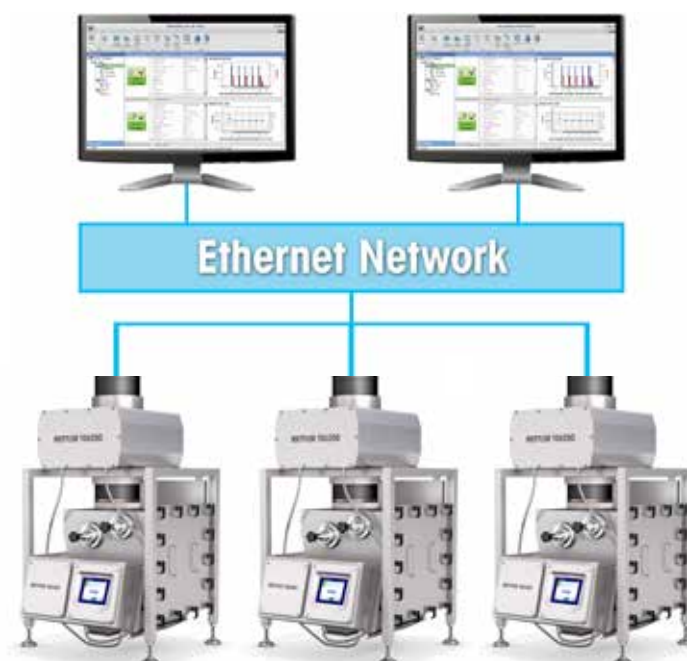

Product Data - Gravity Fall Systems

Model	Nominal Internal Tube Diameter	Typical Throughput Kg/hr*	Overall Length**		Max Fall Height***
			Sealtite / Open Diverter	Y-Valve	
GF 50	50 mm	1500	720 mm	850 mm	350 mm
GFRH 50	50 mm	1500	650 mm	730 mm	300 mm
GF 75	75 mm	3500	873 mm	1000 mm	550 mm
GFRH 75	75 mm	3500	650 mm	810 mm	300 mm
GF 100	102 mm	6000	873 mm	1000 mm	550 mm
GFRH 100	102 mm	6000	650 mm	810 mm	300 mm
GF 125	121 mm	9500	1050 mm	1075 mm	800 mm
GFRH 125	121 mm	9500	850 mm	900 mm	500 mm
GF 150	145 mm	13,500	1050 mm	1150 mm	800 mm
GFRH 150	145 mm	13,500	850 mm	1000 mm	500 mm
GF 200	200 mm	24,000	1217 mm	1400 mm	800 mm
GFRH 200	200 mm	24,000	1100 mm	1200 mm	500 mm
GF 250	250 mm	37,500	1385 mm	1500 mm	800 mm
GF 300	300 mm	56,000	1630 mm	1650 mm	800 mm

Sealtite model: Larger round and rectangular GF systems are available on request for applications that require larger throughput rates

* Actual rates will depend on the bulk density of the product and its flow characteristics; if an ATS is installed, actual throughput rates may be reduced for some configurations)

** Overall length, excluding test kits and heavy duty wash down (HD) systems

*** Distance from inlet flange of the detector to the point where the product starts to fall

Installation in the tightest spaces

All **Gravity Fall** systems use Zero Metal Free Zone (ZMFZ) technology which enables them to be installed close to other metal structures without compromising sensitivity performance. This technology, combined with the compact, innovative reject device design, means that Sealtite and Open Diverter systems offer the best overall space-saving solutions for situations where height is restricted.

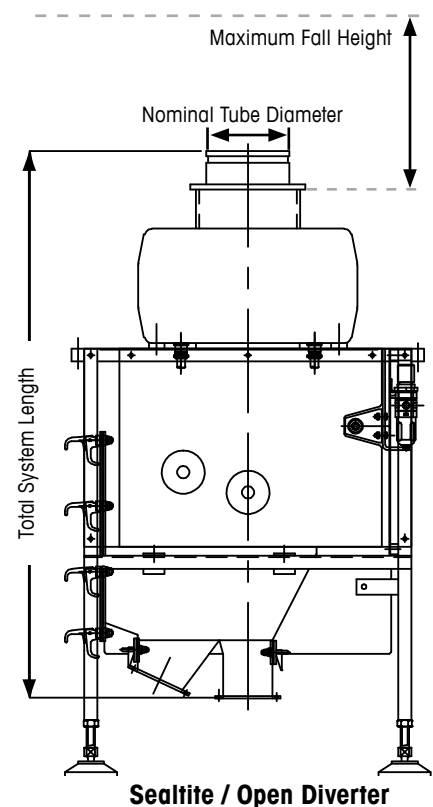
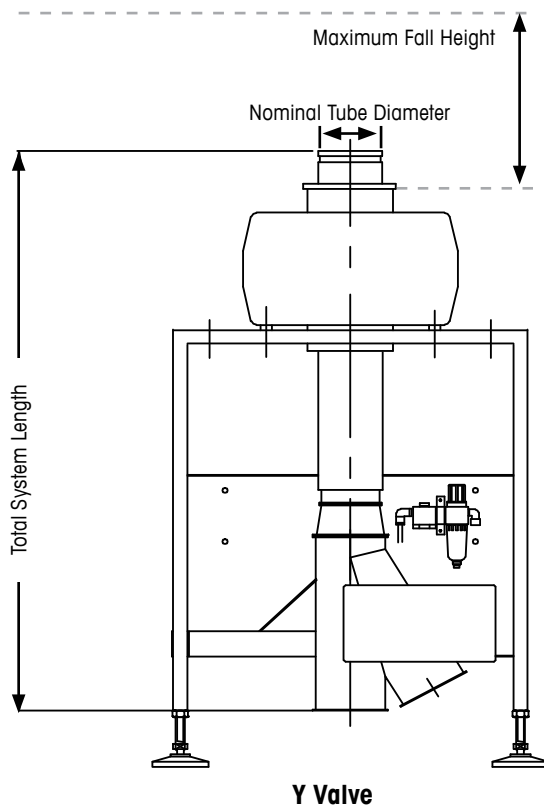

Sensitivity - Gravity Fall Systems

Sensitivities are given as a guide to performance and the data quoted is based on the SAFELINE "boost" performance algorithm being switched out. Achievable sensitivity will be dependent upon the product being inspected, the physical installation of the unit and the final specification of the model chosen. Further improvements in performance may be achieved in some installations by using the SAFELINE "boost" algorithm. eDrive is fitted to standard Gravity Fall models only; eDrive is not available on reduced height (GFRH) models.

Model	Fe	Non-Fe*	SS 316**
GF 50	0.3 mm	0.3 mm	0.4 mm
GFRH 50	0.4 mm	0.4 mm	0.6 mm
GF 75	0.4 mm	0.4 mm	0.6 mm
GFRH 75	0.5 mm	0.5 mm	0.7 mm
GF 100	0.5 mm	0.5 mm	0.7 mm
GFRH 100	0.6 mm	0.6 mm	0.8 mm
GF 125	0.5 mm	0.5 mm	0.8 mm
GFRH 125	0.8 mm	0.8 mm	1.1 mm
GF 150	0.6 mm	0.6 mm	0.8 mm
GFRH 150	0.9 mm	1.0 mm	1.2 mm
GF 200	0.7 mm	0.8 mm	1.0 mm
GFRH 200	1.1 mm	1.3 mm	1.4 mm
GF 250	0.9 mm	1.0 mm	1.1 mm

* Non-Fe includes aluminium, brass, copper, phosphor bronze, etc.

** Stainless Steel sensitivities quoted are for "non-magnetic grades."

Gravity Fall Systems Optional Extras

The following can be specified on all Gravity Fall models:

- Air Failure Alarm
- Integrated test facility with test grid
- ATS Auto Test System*
- Inclined systems
- Reject Confirmation System
- Special throughput tubes for high abrasive non-food applications
- Air-cooled systems for high temperature products
- BFM Fittings

Sealtite models - options





- Circular outlets (rectangular outlets supplied as standard)

*May impact throughput rates, or require system modification. Speak to your local sales representative for further details.

Detecting smaller metal contaminants

For increased brand protection

Gravity Fall metal detection systems with eDrive™ technology outperform conventional metal detection technology, enabling smaller metal contaminants to be found. The table below illustrates how a small improvement in spherical sensitivity can considerably reduce the lengths of wire type contaminants that can be detected.

Metal Detector Specification	316 Stainless Steel Sphere Size				316 Stainless Steel Wire Sample: 0.5mm diameter (worst orientation)			
	2.0 mm ●	1.5 mm ●	1.2 mm ●	1.0 mm ●	50mm long 	25mm long 	15mm long 	5mm long 
1.5mm Fe	✓	✗	✗	✗	✗	✗	✗	✗
1.2mm Fe	✓	✓	✗	✗	✗	✗	✗	✗
1.0mm Fe	✓	✓	✓	✗	✓	✓	✓	✗
0.8mm Fe	✓	✓	✓	✓	✓	✓	✓	✓

Images of spheres and wire lengths above are for illustrative purposes only, and may not be exactly to scale

Benefit from Service

Global Reach and Local Excellence

METTLER TOLEDO Service helps you get the most out of your equipment and provides you with support when and where you need it. We can help you maximize the benefits and the return on investment of your metal detection equipment through its entire lifecycle. Whether you want to achieve improved uptime, better compliance, increased performance or enhanced expertise we can support you.

Uptime

- On-site support
- Spare Parts and Kits
- Repair service

Expertise

- User Training
- Documentation and downloads

Compliance

- Test Samples
- Equipment Qualification
- Performance Verification
- Compliance certificates

Performance

- Setup and configuration
- Professional installation
- Preventative Maintenance
- Upgrade and refurbishment

IPac™ – Creating the documentation to Support Compliance

METTLER TOLEDO Safeline metal detection systems are supplied with an IPac installation and performance verification package to support ongoing compliance with internal and external standards.

This comprehensive package provides full documentation for the installation, commissioning and verification process to meet all audit requirements.



www.mt.com/metaldetection

For more information

METTLER TOLEDO Group
Product Inspection Division
Local contact: www.mt.com/contacts

Subject to technical changes
© 03/17 METTLER TOLEDO. All rights reserved
SLMD-UK-BRO-EN-GF-0717